

**OPERATING FREQUENCIES:**  
 CELL A: 617-960/1710-6000 MHz  
 CELL B: 617-960/1710-6000 MHz  
 CELL C: 617-960/1710-6000 MHz  
 CELL D: 617-960/1710-6000 MHz

ISO VIEW  
 SCALE 1:5

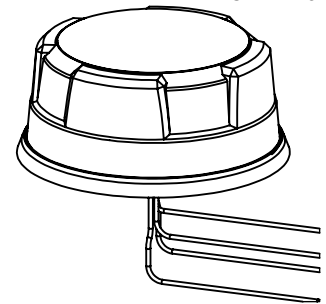

DRG. No.	LPMM4-6-60			SHEET 1 OF 2
PRODUCT/ASSEMBLY	1012 - MIMO AND DIVERSITY ANTENNAS			
DESCRIPTION	4G/5G 4x4 MiMo - WHT			
MATERIAL	N/A			
FINISH	N/A			
WEIGHT	604.5(NET)g			
APPROVED	JJ	DO.CHECK	IC	
SCALE	1:5	DIMENSIONS IN mm		
DO NOT SCALE	3RD ANGLE PROJECTION			
01019	1	PRODUCTION ISSUE	28/05/2020	AA
PCN	REV.	DESCRIPTION	DATE	DRN
TOLERANCES UNLESS OTHERWISE STATED				
0 DEC. PLACE $\pm$ 0.5		2 DEC. PLACES $\pm$ 0.1		
1 DEC. PLACE $\pm$ 0.2		ANGULAR $\pm$ 1°		
	DENOTES LATEST ISSUE CHANGES			DENOTES CRITICAL VALUE
THIS DOCUMENT MUST NOT BE COPIED OR DISCLOSED TO A THIRD PARTY WITHOUT THE WRITTEN CONSENT OF PANORAMA ANTENNAS LTD.				
© 2019			A4	

- NOTES:**
- SAMPLES MUST BE APPROVED BY PANORAMA ANTENNAS Q.C. BEFORE COMMENCING PRODUCTION.
  - ALL MATERIALS SUPPLIED MUST BE RoHS3 (DIRECTIVE (EU) 2015/863) COMPLIANT AND MUST NOT CONTAIN ANY SUBSTANCES OF VERY HIGH CONCERN (SVHCs) LISTED UNDER REACH OR POLY-AROMATIC HYDROCARBONS (PAHs), OR PERSISTENT ORGANIC POLLUTANTS (POPs) CONTROLLED BY THE STOCKHOLM CONVENTION.