

3RD ANGLE PROJECTION		DO NOT SCALE	
TOLERANCES UNLESS OTHERWISE STATED		DENOTES LATEST ISSUE CHANGES	
0 DEC. PLACE ±0.5	2 DEC. PLACES ±0.1	DENOTES CRITICAL VALUE	
1 DEC. PLACE ±0.2	ANGULAR ±1°		

ITEMS SUPPLIED LOOSE

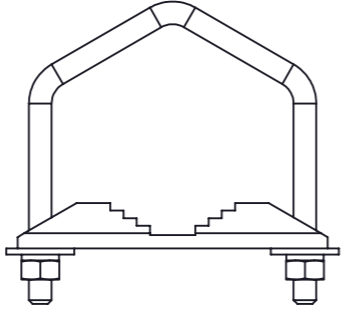

- SAB-165:
- SF3-0011 (x2)-M6 COIL SPRING
 - SF2-0012 (x2)-M6 FULL NUT
 - SF3-0343 (x2)-M6 FLAT WASHER
 - SP4-0013 (x1)-V BOLT
 - SP5-0300 (x1)-MOUNTING BRACKET

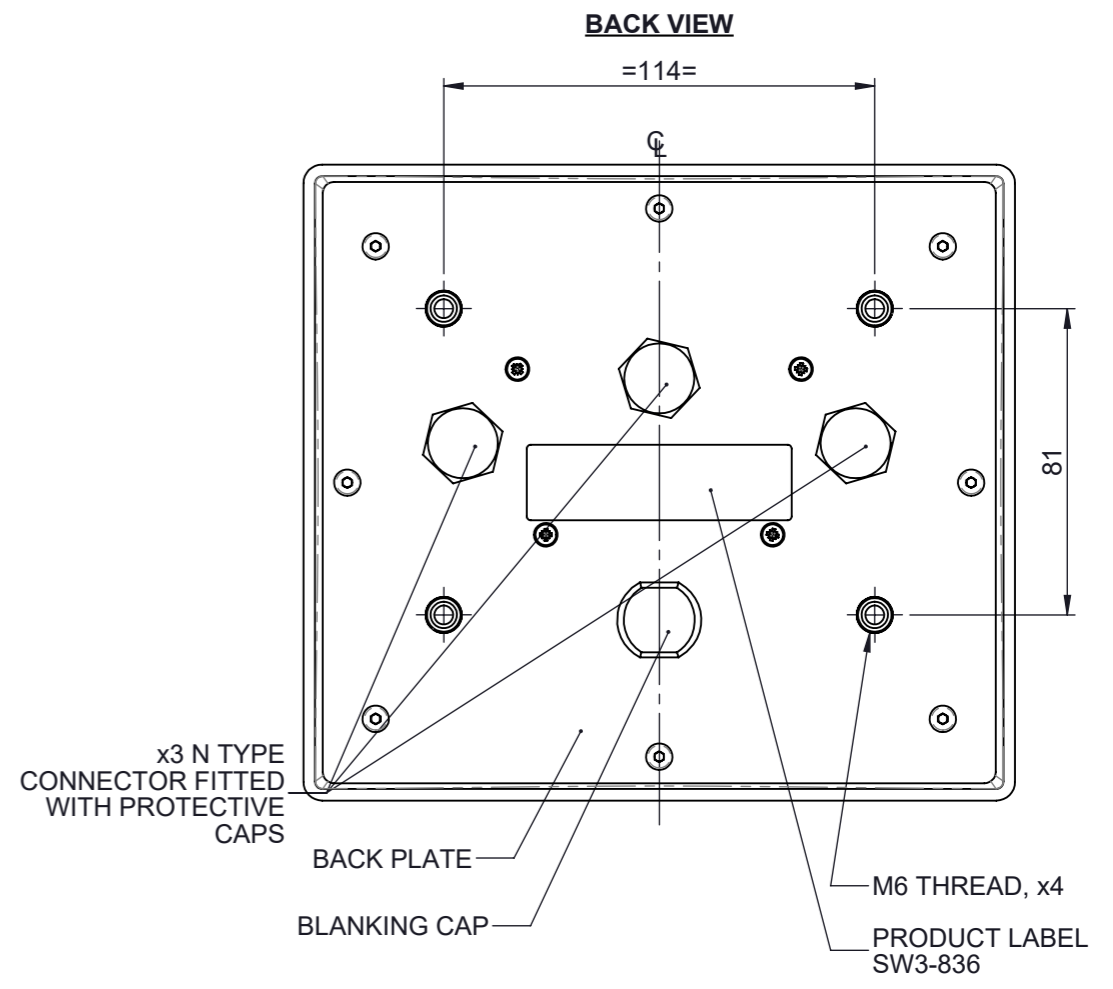
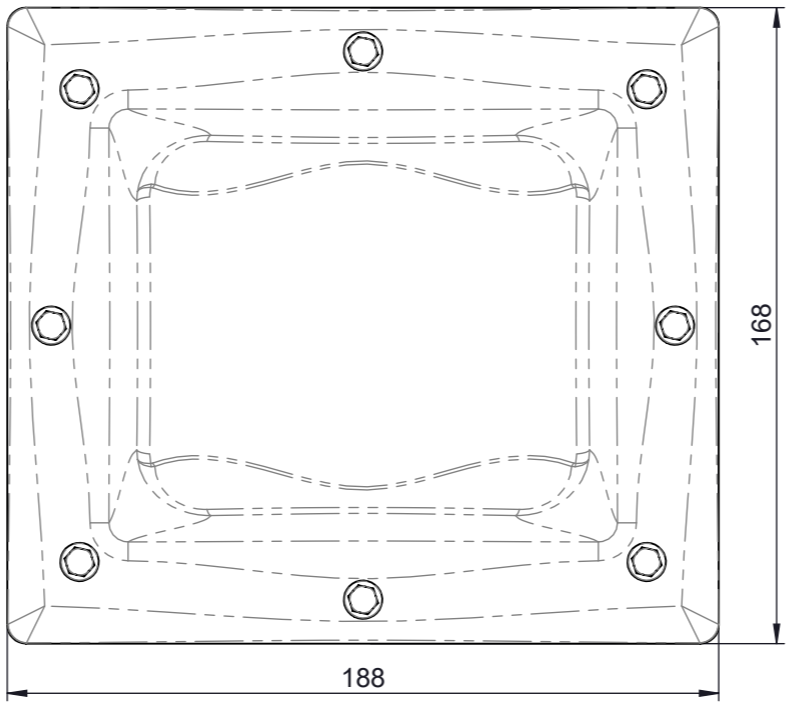
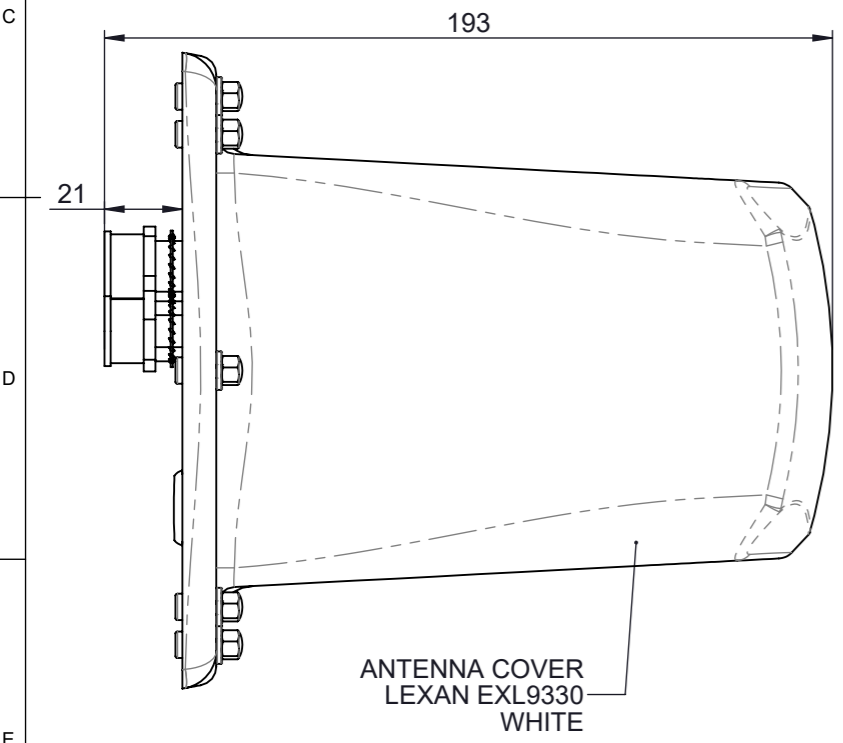
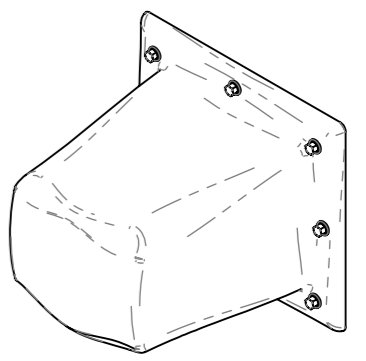

- NOTES:
- SAMPLES MUST BE APPROVED BY PANORAMA ANTENNAS Q.C. BEFORE COMMENCING PRODUCTION.
 - ALL MATERIALS SUPPLIED MUST BE RoHS3 (DIRECTIVE (EU) 2015/863) COMPLIANT AND MUST NOT CONTAIN ANY SUBSTANCES OF VERY HIGH CONCERN (SVHCs) LISTED UNDER REACH OR POLY-AROMATIC HYDROCARBONS (PAHs), OR PERSISTENT ORGANIC POLLUTANTS (POPs) CONTROLLED BY THE STOCKHOLM CONVENTION.

PCN	REV.	DESCRIPTION	DATE	DRN.
01019	A	INITIAL ISSUE	12/12/2019	AR
01019	B	BOM UPDATE	12/02/2020	AR
01019	1	PRODUCTION ISSUE (NO CHANGES)	24/07/2020	AR

PRODUCT/ASSEMBLY 1004 - ELEVATED & FIXED SITE ANTENNAS	
MATERIAL	N/A
FINISH	N/A
WEIGHT	907.68(NET)g
SHEET 1 OF 2	

DESCRIPTION WALL/MST MNT GAIN 3x3MiMo 2.4/5.0GHz			
APPROVED	IC	D.O. CHECK	AA
SCALE	1:5	DIMENSIONS IN mm	

